

TABLE : PIN DEFINE

PIN	SIGNAL NAME	PIN	SIGNAL NAME
A12	GND	B1	GND
A11		B2	
A10		B3	
A9	VBUS	B4	VBUS
A8		B5	
A7	Dn1	B6	
A6	Dp1	B7	
A5	CC	B8	
A4	VBUS	B9	VBUS
A3		B10	
A2		B11	
A1	GND	B12	GND

1. FINISH:

- 1.1 CONTACT: 30u" GOLD PLATED ON CONTACT AREA, 100u"MIN TIN ON SOLDER TAIL, WITH ENTIRE CONTACT UNDERPLATED 80u" NICKEL.
- 1.2 SHELL: 80u" NICKEL PLATED OVERALL.

2. MECHANICAL:

- 2.1 MATING FORCE: 5-20N MAX.
- 2.2 UNMATING FORCE: 8-20N MIN, AFTER 10000 CYCLES: 6-20N
- 2.3 DURABILITY: 10000 CYCLES
- 2.4 OPERATING TEMPERATURE: -40° C ~ 85° C

3. ELECTRICAL:

- 3.1 CURRENT RATING: 5A FOR VBUS PIN; 1.25A FOR VCONN PIN.
- 3.2 DIELECTRIC WITHSTANDING VOLTAGE: 100V AC AT SEA LEVEL.
- 3.3 CONTACT RESISTANCE: 40mΩ MAX.
- 3.4 INSULATION RESISTANCE: 100MΩ MIN

4. SALT SPRAY TEST:

- 4.1 CONCENTRATION IS 5%, THE TEMPERATURE IS 35±°C, TEST TIME 48H MIN, NO OXIDATION OR RUST

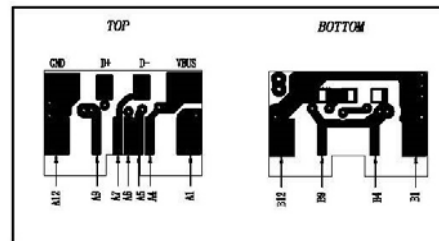
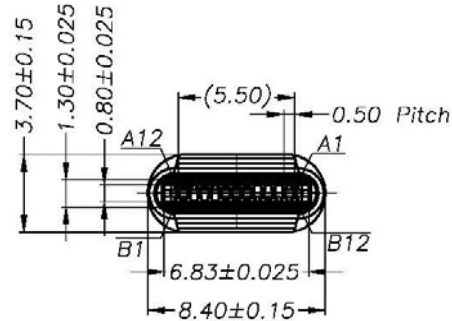
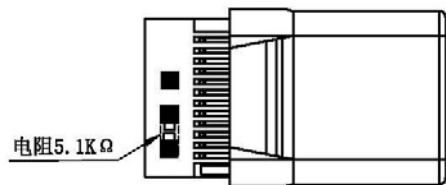
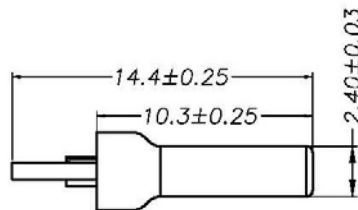
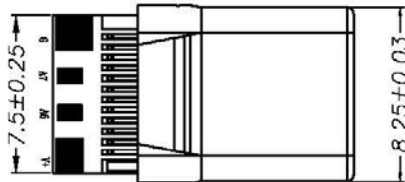
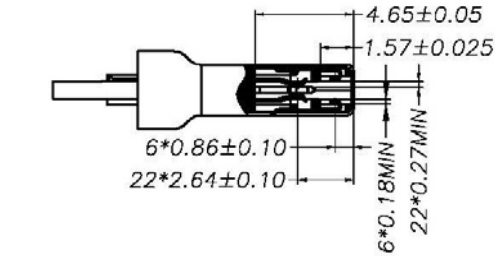

凱帛企業有限公司

KABOE ENTERPRISE CO.,LTD.

Name
USB C SMT R/A 12PIN 帶 PCB 板 拉伸式外殼

Drawing No.
USB C-1011-1291N

D-R -HK- APPD

General Tolerances :
-x.xx±
x.x± Unit : mm Scale : ROM

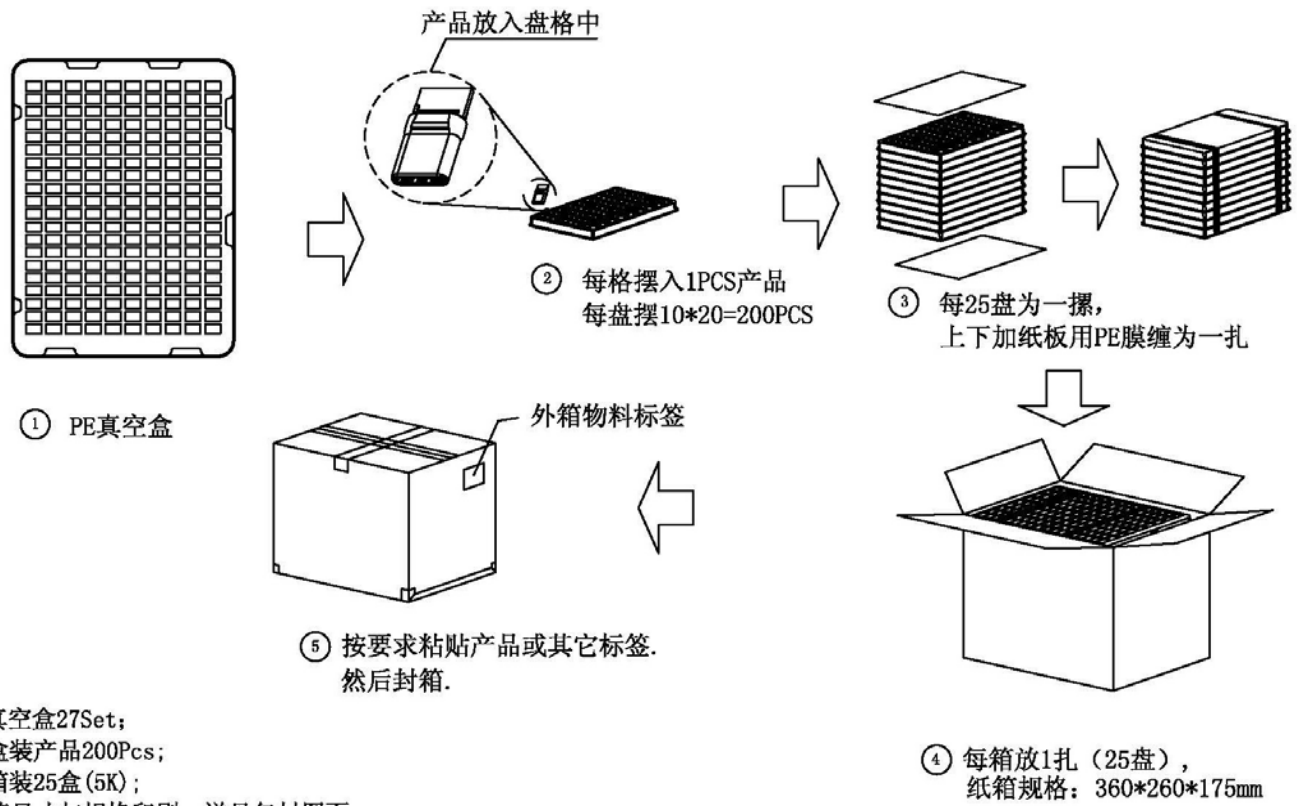

- 备注:
1. PE真空盒27Set;
 2. 每盒装产品200Pcs;
 3. 每箱装25盒(5K);
 4. 外箱尺寸与规格印刷: 详见包材图面;
 5. 外箱用透明胶纸带封箱;

凱帛企業有限公司 KABOE ENTERPRISE CO.,LTD.		
Name USB C SMT R/A 12PIN 帶 PCB 板 拉伸式外殼		
Drawing No. USB C-1011-1291N		
D-R	-HK-	APPD
General Tolerances : -x.xx± x.x±	Unit : mm	Scale : ROM